

Stationary-type non-contact thermometer
For installation in limited space

Measurement range
-40 to 500°C (-40 to 932°F)
0 to 1000°C (32 to 1832°F)

THERMO-HUNTER®
CS series

<-40 to 500°C (-40 to 932°F)>
CS-30TAC/CS-40TAC

<0 to 1000°C (32 to 1832°F)>
CS-30TAC-HT/CS-40TAC-HT



Temperature control of iron plates in hamburger cooking machines

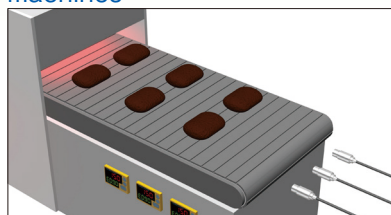

Temperature control during sprocket molding

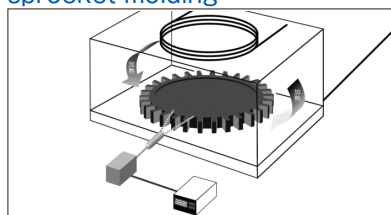

- High environmental durability
- IP69K
- Ultra-compact sensor head
- Digital display
- Simple temp correction
- Analog output
- Hi-temp model

Features

World's smallest-class sensor head ideal for installation in limited space

The ultra-compact head measures only M12 (ø14) × 30 mm. This allows the thermometer to be mounted to a wide variety of equipment in various manufacturing lines.

Heat-resistant sensor head capable of handling up to 180°C (356°F)

The sensor head and cable are heat resistant to 180°C (356°F). This eliminates the need for water cooling even in high-temperature environments. (Low- and medium-temperature models are heat resistant to 100°C (212°F).)

Industry's highest level of waterproof performance

In harsh manufacturing lines, water and dust can cause sensors to fail, so environmental resistance is a must. The CS series offers IP69K protection as stipulated by German standard DIN 40050-9.

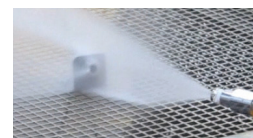

This allows for problem-free use even in high-pressure sterilization washing.

Compact body offering both visibility and operability

The 7-segment, large digital display is incredibly easy to read. In addition, the large, easy-to-understand buttons make operation easier even when mounted to equipment.



2-point teaching function for simple temperature adjustment

The CS series is now equipped with a 2-point teaching function. Setting the upper and lower limits for a measurement target makes adjusting in order to display the desired value easy.

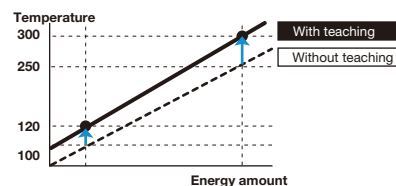

Various measurement modes

Bank function

Settings can be saved independently for banks 1 through 4.

Output scaling function

The temperature range of the analog output (4 to 20 mA) can be set as desired.

Trigger function

Output control can be set according to trigger (synchronization) input. [External trigger / Wave trigger / MAX, MIN, P-P, SAMPLE hold]

Laser pointer for easy alignment (optional)

A laser pointer makes precise positioning easy even with a small head, which is difficult with a conventional setup. Designed to be the same shape as the sensor head, laser pointers can be easily used during alignment.



Type key

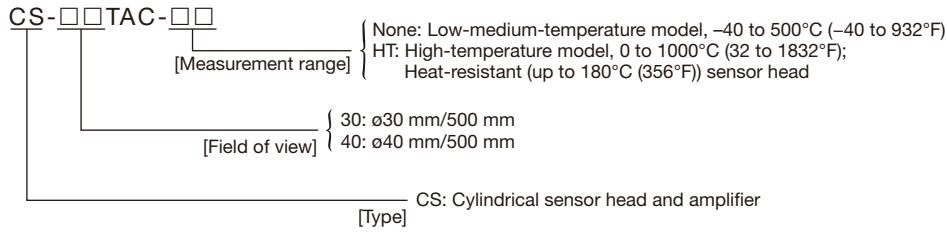

Specifications

Model	Low-medium-temperature models (standard)		High-temperature models (heat-resistant head)	
	CS-30TAC	CS-40TAC	CS-30TAC-HT	CS-40TAC-HT
Measurement range	-40 to 500°C (-40 to 932°F)		0 to 1000°C (32 to 1832°F)	
Field of view	ø30/500 mm (22:1)	ø40/500 mm (15:1)	ø30/500 mm (22:1)	ø40/500 mm (15:1)
Optics	Silicone lens			
Sensing element/ spectral response	Thermopile/8 to 14 µm			
Response time	150 ms/90% response		150 ms/90% response	
Accuracy ^{*1}	-40 to 0°C (-40 to 32°F): ±3°C (5.4°F), 1 to 200°C (33.8 to 392°F): ±2°C (3.6°F), 201 to 500°C (393.8 to 932°F): ±1% of reading value		0 to 200°C (32 to 392°F): ±2°C (3.6°F), 201 to 1000°C (393.8 to 1832°F): ±1% of reading value	
Repeatability	Up to 200°C (392°F): ±1.0°C (1.8°F), 201°C (393.8°F) or more: ±0.5% of reading value			
Emissivity adjustment	0.1 to 1.2			
Display resolution	1°C increments			
Analog output	Output	4 to 20 mA		
	Resolution	0.5°C increments		
	Accuracy	±0.5% or ±1.0°C (1.8°F)		
	Update time	10 ms		
	Allowable load	250 Ω		
Impedance	47 Ω			
Control output	Photo MOS FET × 2 (Transfer contact × 2)			
Capacitive load	300 mA/30 VDC or less			
Interface	Digital output			
Functions	Teaching function: 2 points, Response time selection (DELAY) function: 1 (0.15 sec.) to 200 (approx. 10 sec.), Output scaling function			
External input	Bank function: 4 banks, Synchronous input trigger function, External trigger function, Wave trigger function			
Degree of protection	Sensor head: IP 69K (DIN 40050 Part 9), Amplifier: IP 40 (IEC 60529)			
Vibration resistance	10 to 55 Hz; amplitude 1.5 mm; 2 hours in each of the X, Y, and Z directions			
Supply voltage	12 to 24 VDC ±10%			
Current consumption	120 mA (at max. load) / 80 mA (in Eco mode)			
Ambient temperature	Sensor head: 0 to 100°C (32 to 212°F), Amplifier: 0 to 65°C (32 to 149°F)		Sensor head: 0 to 180°C (32 to 356°F), Amplifier: 0 to 65°C (32 to 149°F)	
Ambient humidity	35 to 85% RH (no condensation)			
Storage temperature	0 to 70°C (32 to 158°F)			
Dimensions	Sensor head: M12 (ø14) × 34 mm, Amplifier: 35 × 52 × 38.5 mm			
Weight	Sensor head: Approx. 100 g (including 3 m cable), Amplifier: Approx. 200 g (including 2 m cable)			
Material	Sensor head: SUS, Amplifier: ABS, Sensor cable: PVC (low-medium-temperature models) / Silicone rubber (high-temperature models)			

*1 The measurement accuracy in the specification is limited to the calibration conditions of our factory.
• Note that specifications are subject to change without prior notice for product improvement purposes.

Selection
guide

Stationary-
type

CS

SA-80

BA

BA-TC

BS

BS-02

BF

Portable-
type

PT-7LD

PT-5LD

PT-S80
PT-U80

PT-2LD

PT-3S

Q & A

Support

Company

Selection guide
Stationary-type
CS
SA-80
BA
BA-TC
BS
BS-02
BF
Portable-type
PT-7LD
PT-5LD
PT-S80 PT-U80
PT-2LD
PT-3S
Q & A
Support
Company

Field of view

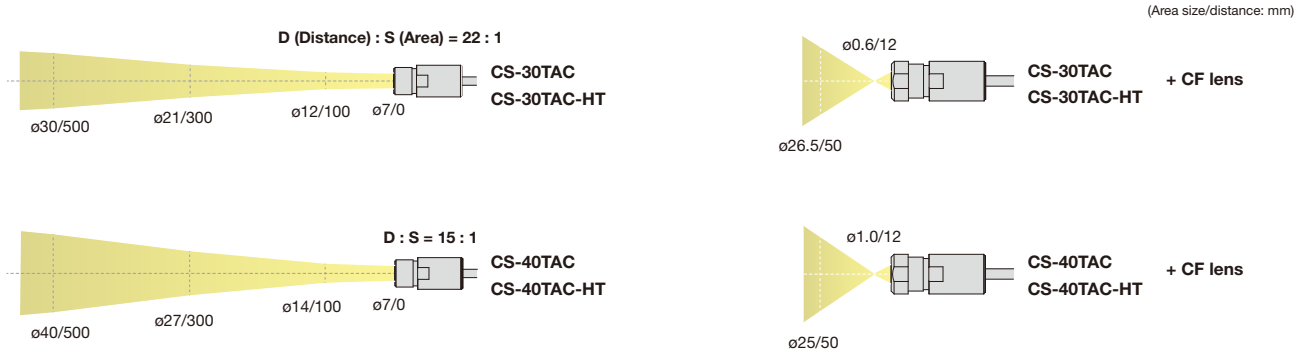

- The fields of view stated above are for an optical response (energy) of 90%.
- The size of the measurement target must be sufficiently larger than the figures shown in the above diagram.

- When a CF lens is equipped, the amount of light received from the measurement target is attenuated by 20 to 30%. Emissivity adjustment is necessary.
- For micro-point measurement, the size of the measurement target must be approx. 1.5 times larger than the measurement field of view shown in the above diagram.

Options/Accessories

Laser pointer

CS-LDP

A laser pointer makes precise positioning easy even with a small head, which is difficult with a conventional setup. Designed to be the same shape as the sensor head, laser pointers can be easily used during alignment.



Warning label

■ Laser beam

- This product uses a Class 2 laser that conforms to IEC 60825-1. Use the product according to the affixed labels.

● Specifications

Supply voltage	3.0 VDC ± 10 % ¹
Wavelength	630-670 nm
Maximum Power	≤1mW (CLASS 2)
Beam Divergence	≤1mrad
Optical Axis Accuracy	± 2°
Ambient Temperature	0 to 40°C
Environmental Humidity	35 to 85%RH (without dew condensation)
Storage Temperature	-10 to 60°C
Vibration Resistance	10 to 55Hz, 1.5 mm amplitude, 2 hours each for XYZ directions with packaging
Degree of Protection	IP40 (IEC 60529)
Materials	Stainless Steel
Weight	Approx. 60 g
Applicable Regulations	RoHS Directive(2011/65/EU), China RoHS(MIT Order No.32) FDA Regulation (21CFR 1040.10 and 1040.11) (expect for deviations pursuant to Laser Notice No.56) ²
Applicable Standards	IEC 60825-1

¹ Do not connect CS-LDP to the same power supply as the CS series amplifier.

² Design and specifications are subject to change for product improvement without prior notice.

CF lens

CS-CF01

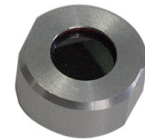

Air purge pipe

CS-AP1



Mounting bracket (for sensor head)

CS-FB12



Black tape for glossy objects

HB-250



Dimensions

● Sensor head

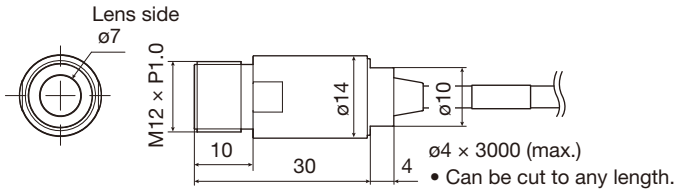

With CF lens

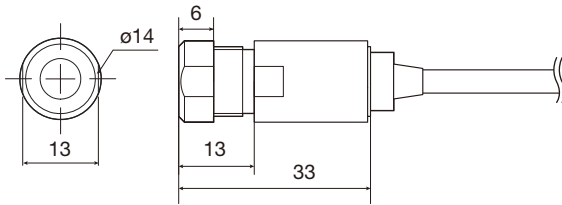

● Amplifier

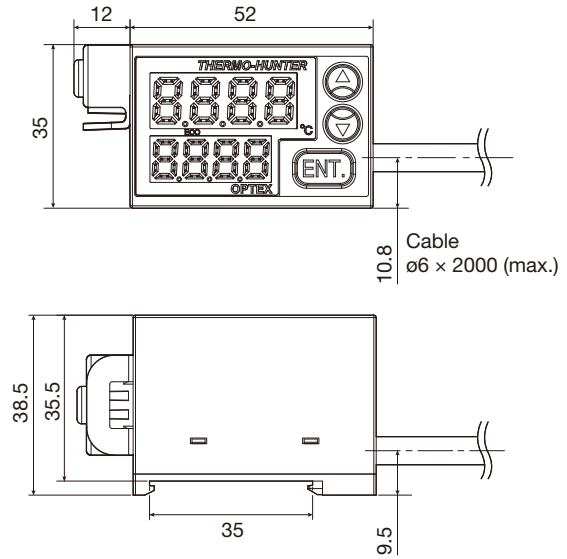

● Mounting bracket CS-FB12

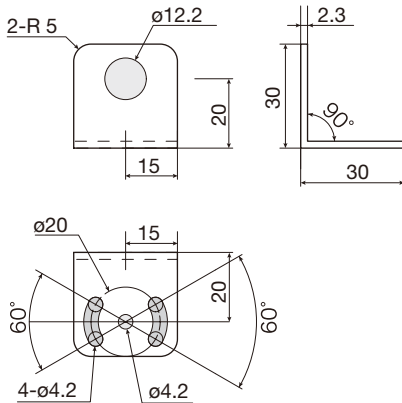

(Unit:mm)

Selection
guide

Stationary-
type

CS

SA-80

BA

BA-TC

BS

BS-02

BF

Portable-
type

PT-7LD

PT-5LD

PT-S80
PT-U80

PT-2LD

PT-3S

Q & A

Support

Company